

Surprisingly tough multi-purpose manual equipment for large workpieces and heavy objects.



Wet blasting equipment for heavy objects

MS-12

1. Can handle heavy loads up to 50 kg

Can handle 5 times MRB-7's maximum load.

MS-12 can handle the loading and unloading of workpieces using a crane.

It can also handle heavy loads (max 50 kg, Φ750×H600 mm) that MRB-7 and MS-11 cannot handle.

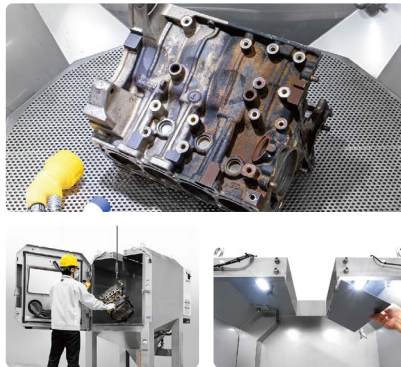

MS-12 was developed for handling heavy loads.

The top section can be easily opened and closed so parts can be loaded or unloaded using a crane. The standard work table can easily handle 50 kg, which is 5 times the load MRB-7 can handle. The large cabinet can handle over 3 times the volume of workpieces than that of MRB-7.

Of course, it has the same high wear resistance as MS-11 and is surprisingly tough. It is a professional model that can handle heavy usage. As with our other models, it is easy to use and easy to manage.

In terms of quality, it can handle all sizes of parts and is the top of the line of our manual product lineup.

2. Compatible with a wide range of applications

Polygonal abrasives can be used. It can be used for various applications.

The rugged rotary table in the cabinet makes it easy to completely process large and heavy objects. An air blow gun is also standard with this equipment. Water draining is also done quickly and completely.



Paint peeling and cleaning of aluminum cylinders



Paint peeling of steel fuel tank



Removing of weld on stainless steel parts



Paint peeling of resin cover

3. Comfortable usability

Large window and bright chamber give you high workability.

The large window and bright lighting give you a stress-free work environment.

The large chamber and the rotary table designed to handle heavy objects make it easy to rotate the parts. Also, 5 color variations are available, including basic brown.

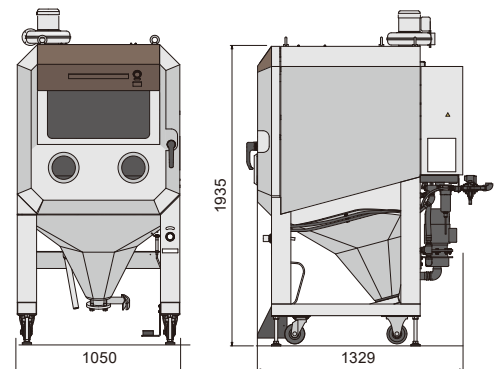

Dimensions W1050×D1329×H1935mm

Inner diameters (mm)

Load Capacity	50kg
Power	AC200V3Phase 15A
Air consumption	700L/min
Weight	325kg